

# \*\*\* FUSION MOUNT INSTALLATION INSTRUCTIONS \*\*\*

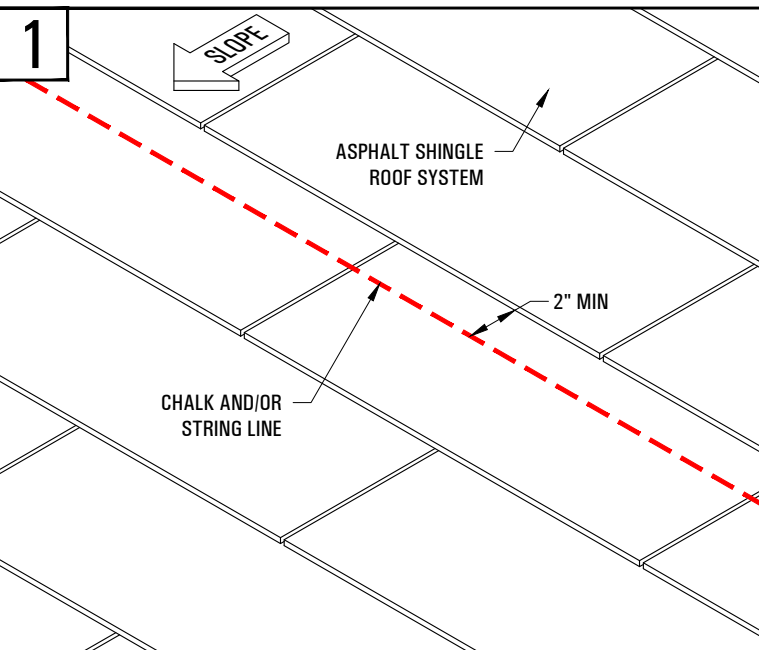

MEASURE THE DISTANCE FROM EAVE TO THE FIRST ROW OF FUSION MOUNTS. THEN, USE A CHALK AND/OR STRING LINE OVER THE TOP OF THE ROOF SHINGLES, AND ESTABLISH IT A MINIMUM OF 2" FROM THE UP SLOPE DRIP EDGE OF THE ASPHALT SHINGLE ROW ABOVE, TO ESTABLISH A STRAIGHT GUIDELINE FOR INSTALLATION.

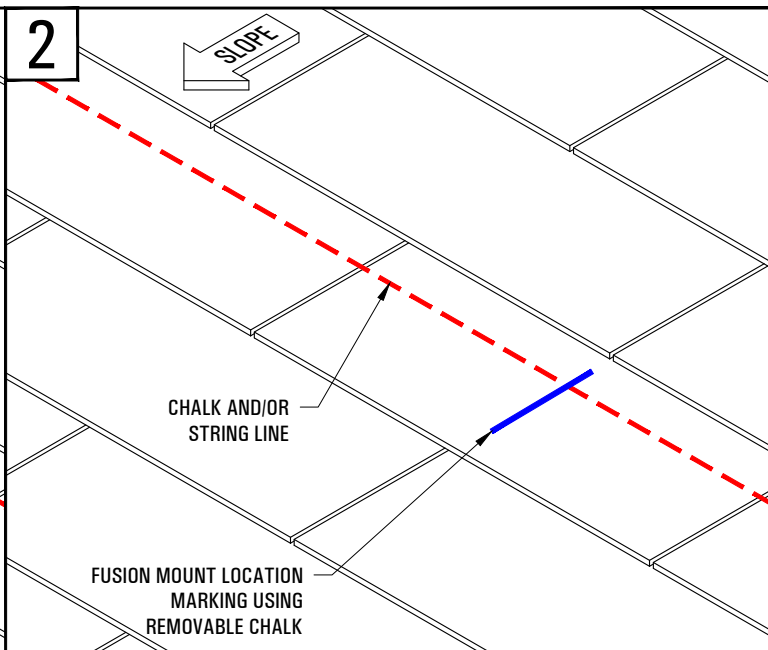

MEASURE AND MARK THE FUSION MOUNT LOCATIONS PER THE RACKING SYSTEM'S ALLOWABLE SPAN OF ATTACHMENT BETWEEN FUSION MOUNTS.

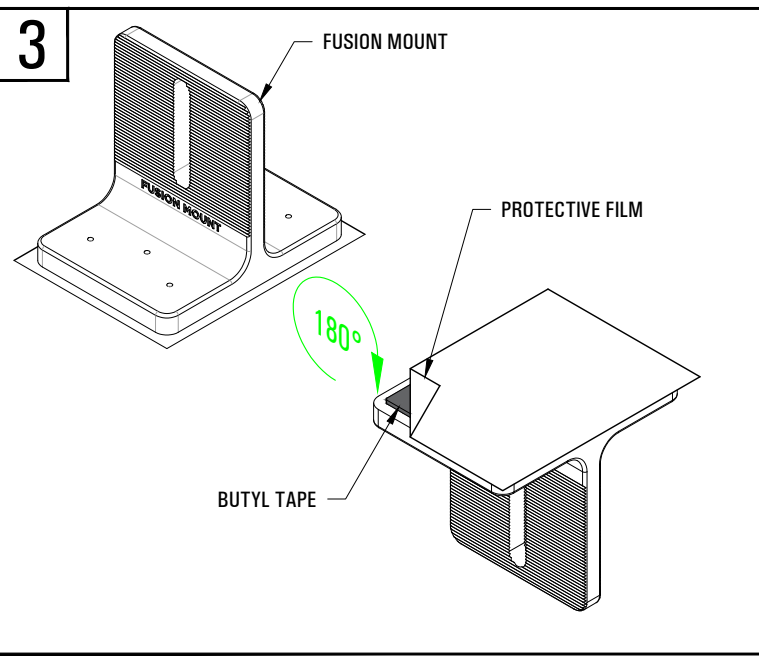

FLIP THE FUSION MOUNT OVER AND REMOVE THE PROTECTIVE FILM TO EXPOSE THE FUSION MOUNT'S BUTYL TAPE PAD.

NOTE: **DO NOT** APPLY SEALANT TO THE BOTTOM OF THE FUSION MOUNT, OR OVER THE BUTYL TAPE PAD.

NOTE: INSPECT THE EXPOSED BUTYL TAPE PAD TO ASSURE IT IS FREE FROM ANY DIRT AND/OR DEBRIS THAT MAY INHIBIT PROPER BUTYL ADHESION.

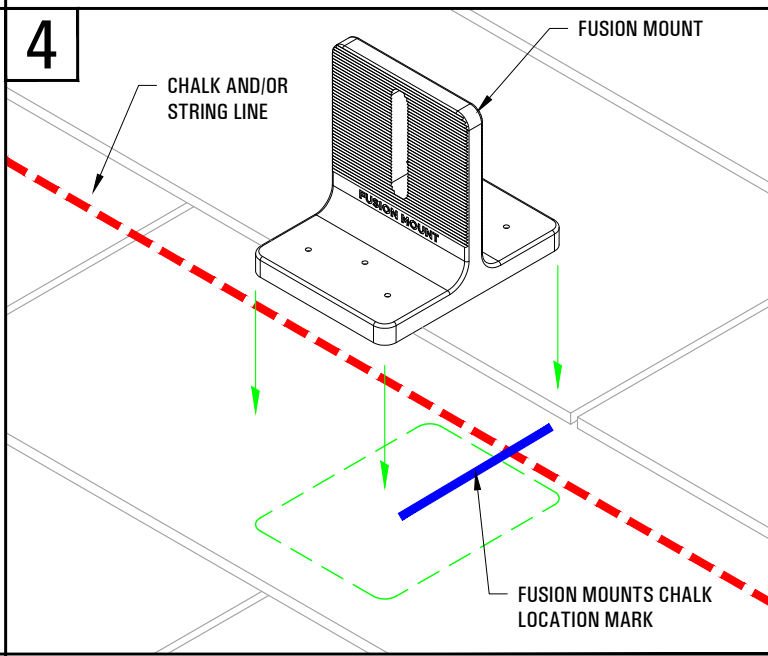

BRUSH AWAY ANY DIRT AND/OR DEBRIS FROM THE ASPHALT SHINGLE ROOF SURFACE, LINE UP THE TOP EDGE OF THE FUSION MOUNT WITH THE CHALK AND/OR STRING LINE WHERE IT INTERSECTS THE CHALK LOCATION MARKING, THEN PLACE THE FUSION MOUNT ON THE ASPHALT SHINGLE ROOF SURFACE.

NOTE: DOUBLE CHECK ALL MEASUREMENTS AND LOCATION PRIOR TO PLACING THE FUSION MOUNT ONTO THE ASPHALT SHINGLE ROOF SURFACE.

NOTE: EXCESSIVE FORCE IS NOT REQUIRED FOR THE FUSION MOUNT INSTALLATION.

## FUSION MOUNT INSTALLATION



220 EXCHANGE DRIVE, UNIT B, CRYSTAL LAKE, IL 60014

PHONE: 800.815.7652 WEBSITE: WWW.SOLARCONNECTIONS.COM  
 FAX: 815.455.4367 E-MAIL: INFO@SOLARCONNECTIONS.COM

### DISCLAIMER

THE INFORMATION HEREIN IS CONFIDENTIAL AND PROPRIETARY AND IS NOT TO BE DISCLOSED OR DELIVERED TO THIRD PARTIES WITHOUT THE PRIOR WRITTEN CONSENT OF SOLAR CONNECTIONS INTERNATIONAL, INC.

SOLAR CONNECTIONS INTERNATIONAL, INC. DOES NOT WARRANT THE INSTALLATION IF ITS PRODUCTS. PRODUCT PERFORMANCE IS DEPENDENT ON THE INSTALLERS STRICT ADHERENCE TO THESE INSTALLATION INSTRUCTIONS.

SOLAR CONNECTIONS INTERNATIONAL, INC. IS NOT A LICENSED ARCHITECT OR ENGINEER, THEREFORE WE STRONGLY RECOMMEND THAT AN ARCHITECT AND/OR STRUCTURAL ENGINEER PROPERLY LICENSED IN THE CITY AND STATE WHERE THE PROJECT IS LOCATED, REVIEW THE CONTEMPLATED LAYOUT TO ENSURE THAT THE BUILDING STRUCTURE CAN WITHSTAND THE PROJECTED SNOW AND/OR WIND LOAD. SOLAR CONNECTIONS INTERNATIONAL, INC. ASSUMES NO LIABILITY THEREFORE.

DRAWN BY:	RJH
DATE:	12/8/25
SCALE:	N.T.S.

1

# \*\*\* FUSION MOUNT INSTALLATION INSTRUCTIONS \*\*\*

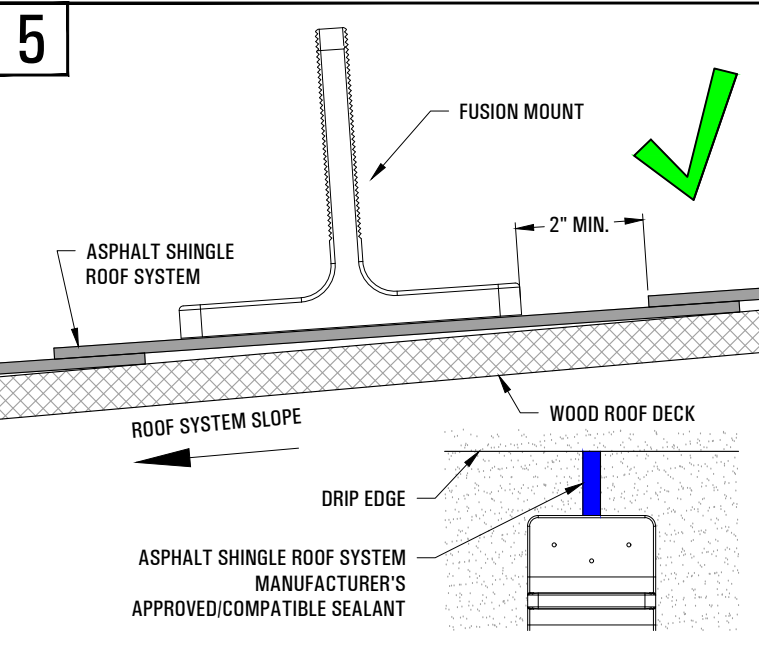

ENSURE THE FUSION MOUNT IS POSITIONED FLAT NEAR THE CENTER OF THE ASPHALT SHINGLE.

NOTE: AVOID PLACING THE FUSION MOUNT DIRECTLY OVER ASPHALT SHINGLE KEYWAYS AND / OR BUTT JOINTS. IF THIS IS UNAVOIDABLE, FILL THE KEYWAY OR BUTT JOINT FROM THE TOP EDGE OF THE FUSION MOUNT TO THE SHINGLE COURSE ABOVE WITH THE ASPHALT SHINGLE ROOF SYSTEM MANUFACTURER'S APPROVED/COMPATIBLE SEALANT, AS SHOWN ABOVE ONLY.

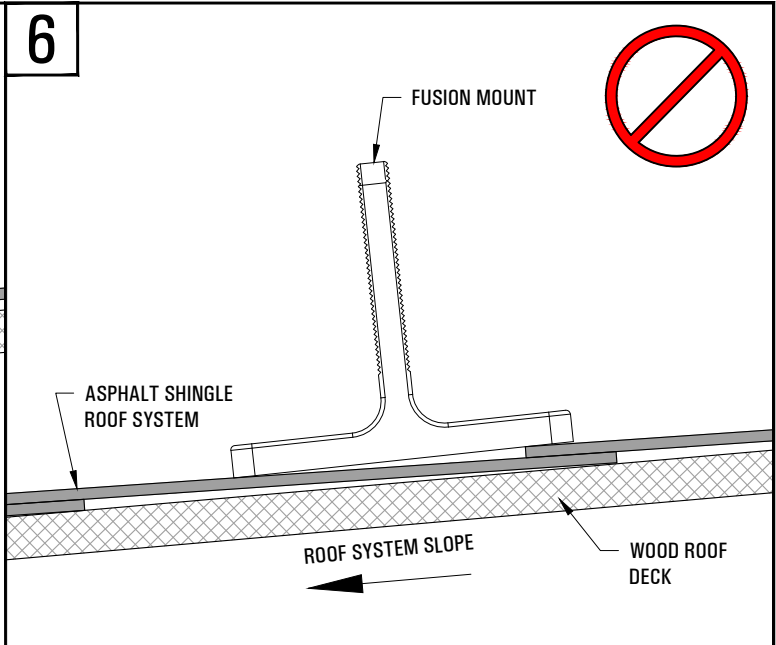

DO NOT INSTALL THE FUSION MOUNT OVER THE HORIZONTAL DRIP EDGE OF EITHER THE SHINGLE ROW ABOVE OR BELOW THE ASPHALT SHINGLE INSTALLATION PLACEMENT ROW.

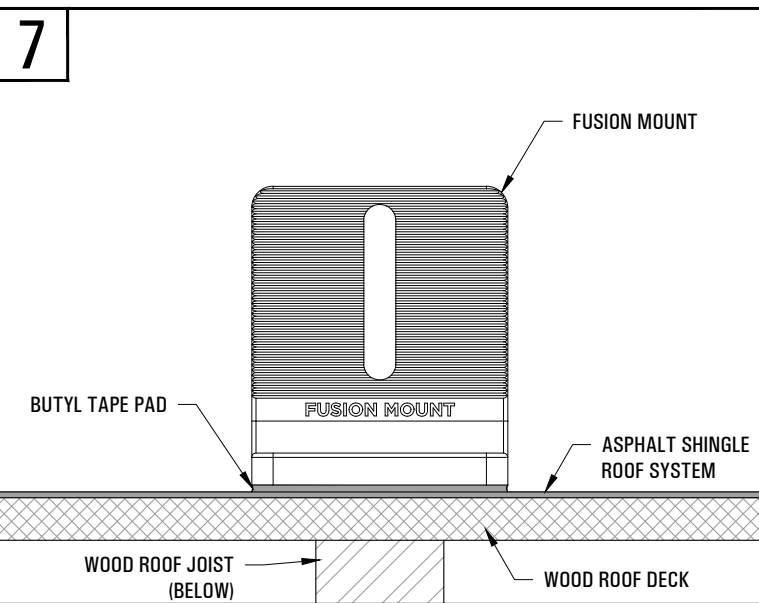

WHEN INSTALLING DIRECTLY OVER A ROOF JOIST, TWO 2" COATED #14 SELF-TAPPING SCREW FASTENERS WITH EPDM WASHERS ARE NEEDED.

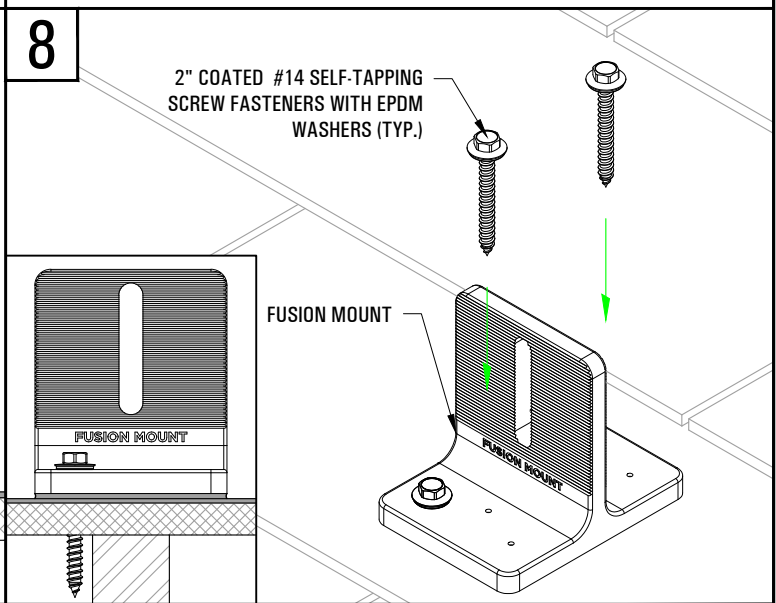

IF ONE OF THE TWO SOLAR CONNECTIONS INTERNATIONAL SUPPLIED 2" COATED #14 SELF-TAPPING SCREW FASTENERS WITH EPDM WASHERS MISSES THE ROOF JOIST BELOW, KEEP ADDING SOLAR CONNECTIONS INTERNATIONAL SUPPLIED 2" COATED #14 SELF-TAPPING SCREW FASTENERS WITH EPDM WASHERS UNTIL TWO ARE SECURELY FASTENED DIRECTLY INTO THE ROOF JOIST BELOW, OR WHEN ALL SIX FASTENERS ARE INSTALLED INTO THE WOOD ROOF DECK BELOW, ONLY.

NOTE: **DO NOT** REMOVE ANY SCREW FASTENERS THAT MISS THE ROOF JOIST, IF THE FUSION MOUNT WILL SUPPORT THE INTENDED PURPOSE OF ITS INSTALLATION. IF IT WILL NOT, SIMPLY REMOVE THE FASTENERS AND FUSION MOUNT, AND FOLLOW THE ASPHALT SHINGLE ROOF SYSTEM MANUFACTURER'S INSTRUCTIONS FOR PROPERLY REPAIRING THE ASPHALT SHINGLE ROOF SYSTEM, WHERE THAT FUSION MOUNT WAS INSTALLED THEN REMOVED (TYP.).

## FUSION MOUNT INSTALLATION (CON'T)



220 EXCHANGE DRIVE, UNIT B, CRYSTAL LAKE, IL 60014

PHONE: 800.815.7652 WEBSITE: WWW.SOLARCONNECTIONS.COM  
 FAX: 815.455.4367 E-MAIL: INFO@SOLARCONNECTIONS.COM

### DISCLAIMER

THE INFORMATION HEREIN IS CONFIDENTIAL AND PROPRIETARY AND IS NOT TO BE DISCLOSED OR DELIVERED TO THIRD PARTIES WITHOUT THE PRIOR WRITTEN CONSENT OF SOLAR CONNECTIONS INTERNATIONAL, INC.

SOLAR CONNECTIONS INTERNATIONAL, INC. DOES NOT WARRANT THE INSTALLATION IF ITS PRODUCTS. PRODUCT PERFORMANCE IS DEPENDENT ON THE INSTALLERS STRICT ADHERENCE TO THESE INSTALLATION INSTRUCTIONS.

SOLAR CONNECTIONS INTERNATIONAL, INC. IS NOT A LICENSED ARCHITECT OR ENGINEER, THEREFORE WE STRONGLY RECOMMEND THAT AN ARCHITECT AND/OR STRUCTURAL ENGINEER PROPERLY LICENSED IN THE CITY AND STATE WHERE THE PROJECT IS LOCATED, REVIEW THE CONTEMPLATED LAYOUT TO ENSURE THAT THE BUILDING STRUCTURE CAN WITHSTAND THE PROJECTED SNOW AND/OR WIND LOAD. SOLAR CONNECTIONS INTERNATIONAL, INC. ASSUMES NO LIABILITY THEREFORE.

DRAWN BY:	RJH
DATE:	12/8/25
SCALE:	N.T.S.

2

# \*\*\* FUSION MOUNT INSTALLATION INSTRUCTIONS \*\*\*

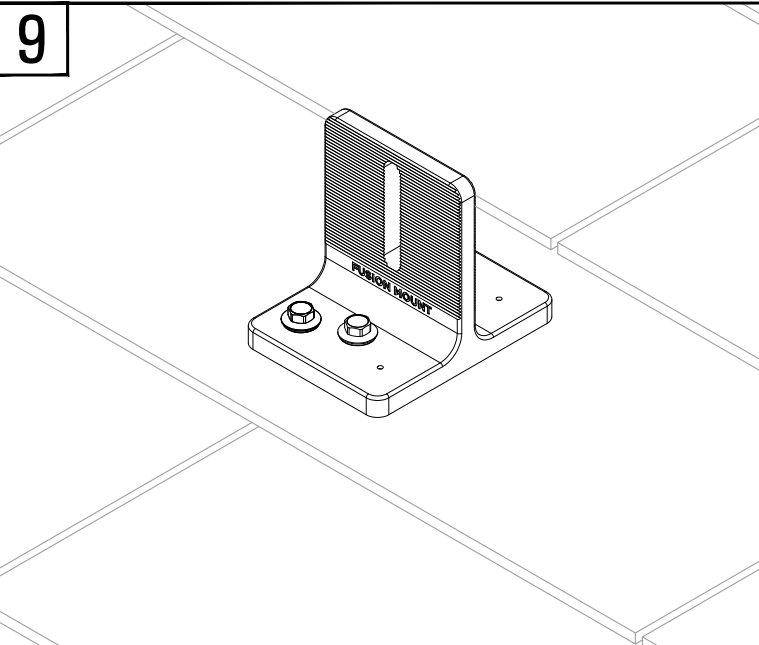

**9**

IF YOU ARE ABLE TO LOCATE THE ROOF JOIST WITH 2 SOLAR CONNECTIONS INTERNATIONAL SUPPLIED 2" COATED #14 SELF TAPPING SCREW FASTENERS, AND AFTER SECURING THE FUSION MOUNT AND TIGHTENING THE SCREW FASTENERS, INSPECT THE EPDM WASHERS ENSURING THEY ARE PROPERLY COMPRESSED.

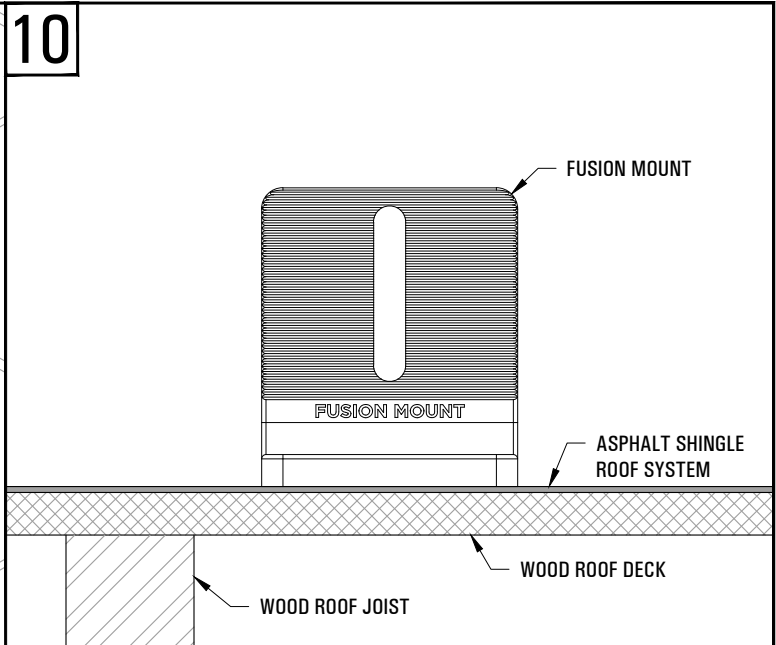

**10**

WHEN NOT INSTALLING DIRECTLY OVER A ROOF JOIST, SIX PROPERLY INSTALLED SOLAR CONNECTIONS INTERNATIONAL SUPPLIED 2" COATED #14 SELF-TAPPING SCREW FASTENERS WITH EPDM WASHERS WILL NEED TO BE USED.

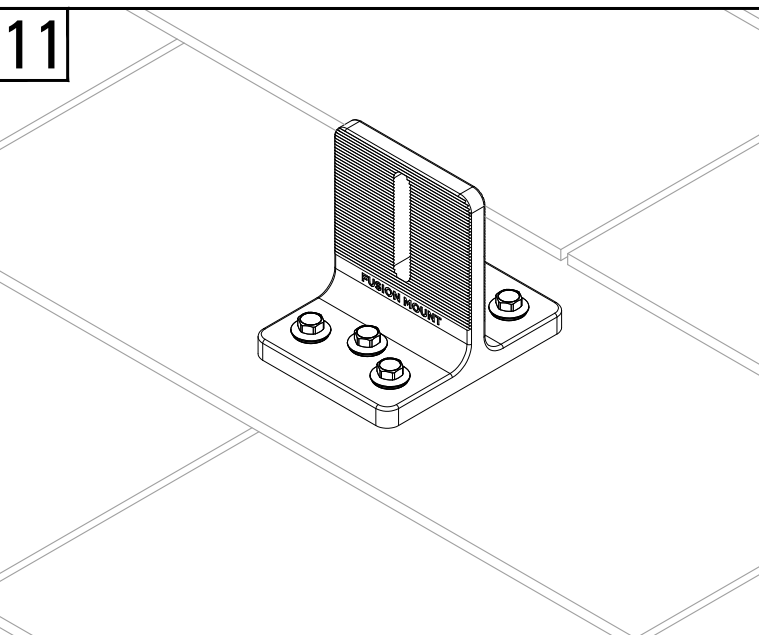

**11**

IF ALL SIX SOLAR CONNECTIONS INTERNATIONAL SUPPLIED 2" COATED #14 SELF-TAPPING SCREW FASTENERS ARE INSTALLED, AND AFTER SECURING THE FUSION MOUNT AND TIGHTENING THE SCREWS, INSPECT THE EPDM WASHERS TO ENSURE THEY ARE PROPERLY COMPRESSED.

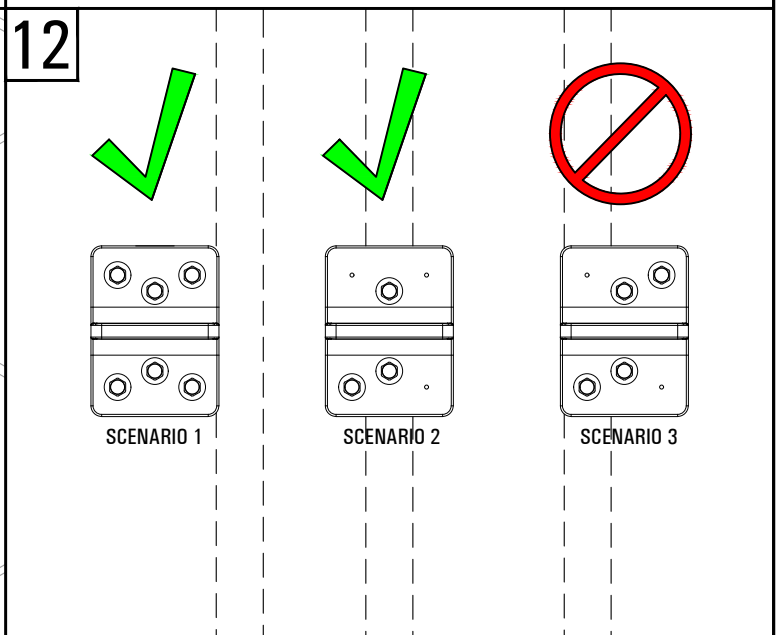

**12**

SCENARIO 1: IN THIS CASE ALL SIX PROPERLY INSTALLED SOLAR CONNECTIONS INTERNATIONAL SUPPLIED 2" COATED #14 SELF-TAPPING SCREW FASTENERS WITH EPDM WASHERS ARE USED.  
 SCENARIO 2: IN THIS CASE AT LEAST TWO PROPERLY INSTALLED SOLAR CONNECTIONS INTERNATIONAL SUPPLIED 2" COATED #14 SELF-TAPPING SCREW FASTENERS WITH EPDM WASHERS ARE SECURELY FASTENED TO THE ROOF JOIST BELOW.  
 SCENARIO 3: IN THIS CASE ONLY ONE OR NONE OF THE INSTALLED SOLAR CONNECTIONS INTERNATIONAL SUPPLIED 2" COATED #14 SELF-TAPPING SCREW FASTENERS WITH EPDM WASHERS ARE SECURELY FASTENED TO THE ROOF JOIST, AND NOT ALL SIX FASTENERS WERE USED.

## FUSION MOUNT INSTALLATION (CON'T)



220 EXCHANGE DRIVE, UNIT B, CRYSTAL LAKE, IL 60014

PHONE: 800.815.7652 WEBSITE: WWW.SOLARCONNECTIONS.COM  
 FAX: 815.455.4367 E-MAIL: INFO@SOLARCONNECTIONS.COM

### DISCLAIMER

THE INFORMATION HEREIN IS CONFIDENTIAL AND PROPRIETARY AND IS NOT TO BE DISCLOSED OR DELIVERED TO THIRD PARTIES WITHOUT THE PRIOR WRITTEN CONSENT OF SOLAR CONNECTIONS INTERNATIONAL, INC.

SOLAR CONNECTIONS INTERNATIONAL, INC. DOES NOT WARRANT THE INSTALLATION IF ITS PRODUCTS. PRODUCT PERFORMANCE IS DEPENDENT ON THE INSTALLERS STRICT ADHERENCE TO THESE INSTALLATION INSTRUCTIONS.

SOLAR CONNECTIONS INTERNATIONAL, INC. IS NOT A LICENSED ARCHITECT OR ENGINEER, THEREFORE WE STRONGLY RECOMMEND THAT AN ARCHITECT AND/OR STRUCTURAL ENGINEER PROPERLY LICENSED IN THE CITY AND STATE WHERE THE PROJECT IS LOCATED, REVIEW THE CONTEMPLATED LAYOUT TO ENSURE THAT THE BUILDING STRUCTURE CAN WITHSTAND THE PROJECTED SNOW AND/OR WIND LOAD. SOLAR CONNECTIONS INTERNATIONAL, INC. ASSUMES NO LIABILITY THEREFORE.

DRAWN BY:	RJH
DATE:	12/8/25
SCALE:	N.T.S.

**3**